

# NUURA

Light efficiency:



Light quality:



Color temperature:



Output: 255 lm

Peak: 66,3 cd

Power: 5,8 W

PF: 0,99

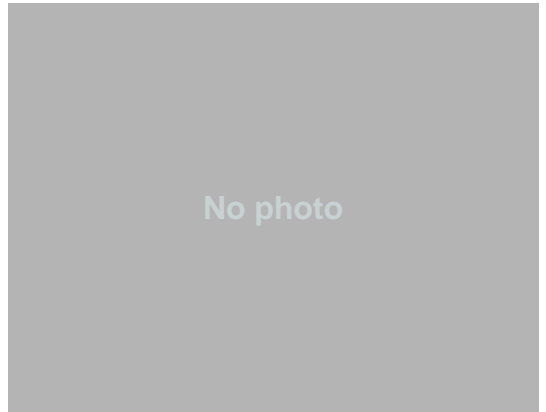

Product name:

**B-4496 Blossi Table 6W**

Item number:

Date and time:

**2019-04-23 22:55:53**

Description:

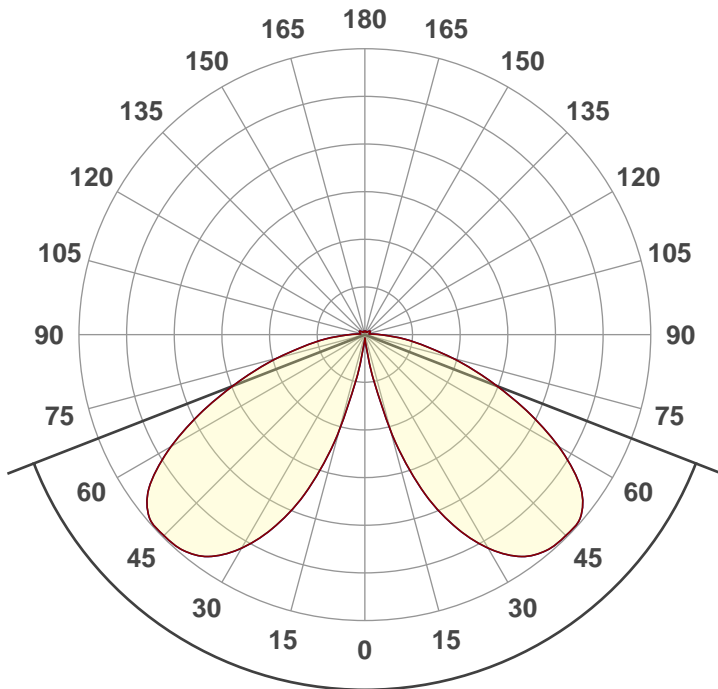

Beam angle

**137,5°**



CIE 1931  
x: 0,469  
y: 0,411

Spectra

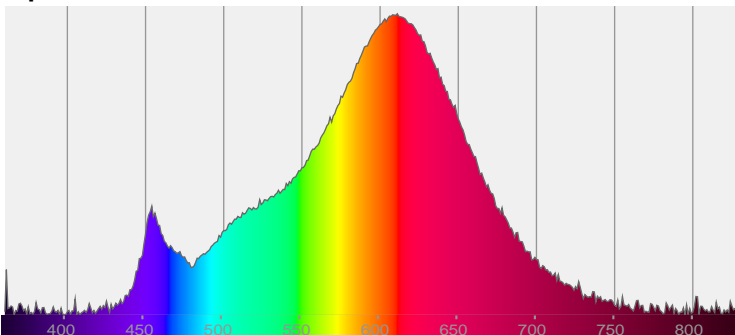

Power

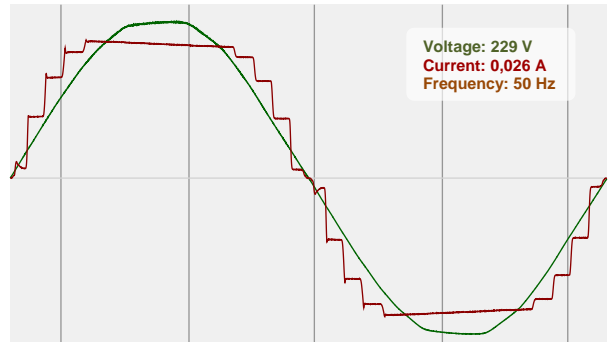

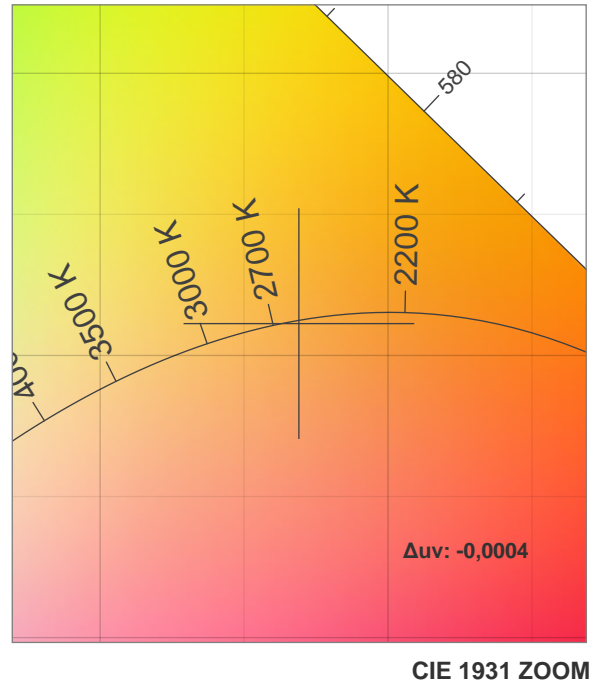
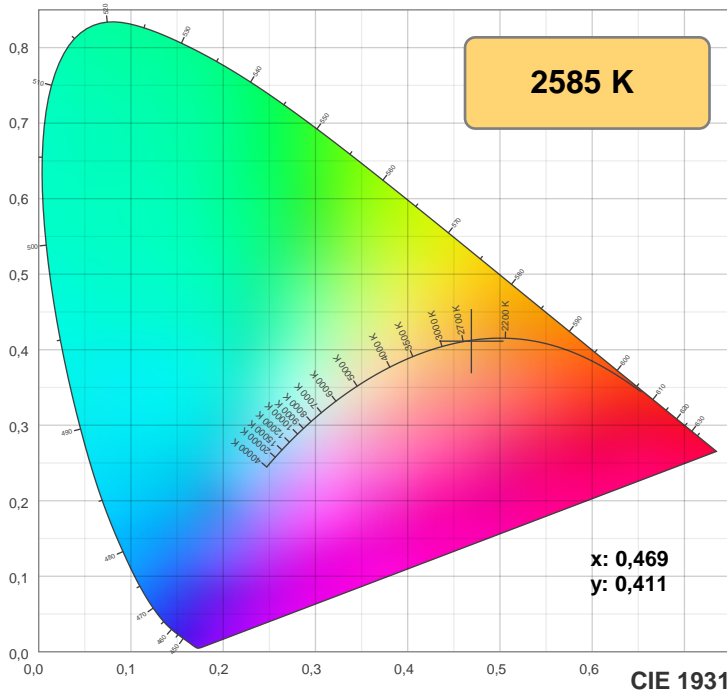

**TM30: 84,8**

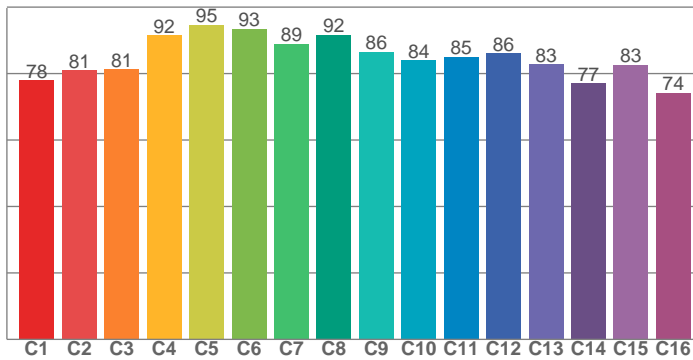

**CRI: 84,1 (R1-R8)**

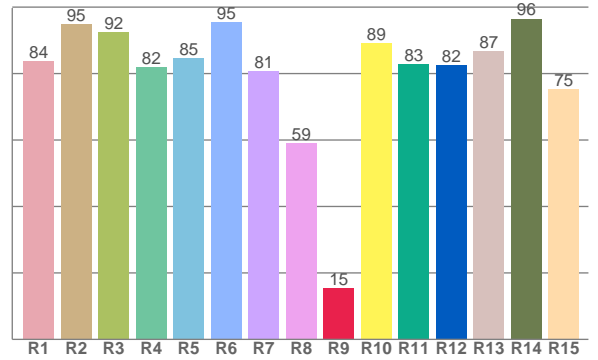

**CQS: 83,6**

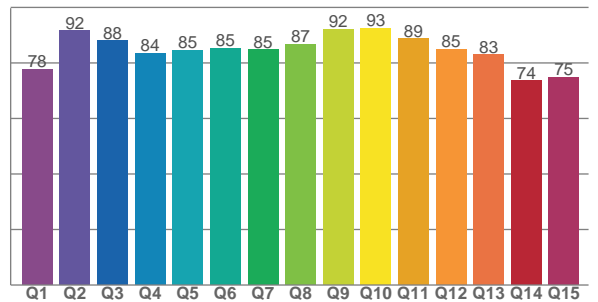

CRI R values, only R1-R8 are used to calculate final CRI value

R1	R2	R3	R4	R5	R6	R7	R8	R9	R10	R11	R12	R13	R14	R15
83,8	94,8	92,4	82,0	84,6	95,4	80,8	59,1	15,3	89,1	82,8	82,5	86,6	96,5	75,2

TM30 C values, 16 binned values out of total of 99 C values

C1	C2	C3	C4	C5	C6	C7	C8	C9	C10	C11	C12	C13	C14	C15	C16
78,0	81,0	81,3	91,5	94,7	93,4	88,9	91,6	86,4	83,9	85,1	86,1	82,8	77,0	82,6	74,1

CQS Q values

Q1	Q2	Q3	Q4	Q5	Q6	Q7	Q8	Q9	Q10	Q11	Q12	Q13	Q14	Q15
77,8	91,6	88,1	83,5	84,6	85,3	84,7	86,7	92,2	92,5	88,7	85,0	83,1	73,5	74,9

### Color parameters

Color temperature	Color rendering index	Red component	Color fidelity	Color gamut	Color quality scale	Color coordinate cie 1931	Color coordinate cie 1931	Color coordinate	Color coordinate	Color deviation from black body
CCT	CRI	CRI R9	TM30 Rf	TM30 Rg	CQS	x	y	u	v	$\Delta uv$
2585 K	84,1	15,3	84,8	94,6	83,6	0,469	0,411	0,268	0,353	-0,0004

**Rf 84,8**  
Fidelity index Rf

**Rg 94,6**  
Gammut index Rg

Hue Bin	R <sub>f</sub>	Graphic shifts (%)	
		Chroma	Hue
1	78	-11%	2%
2	81	-7%	6%
3	81	-3%	8%
4	92	-2%	2%
5	95	-1%	2%
6	93	0%	0%
7	89	-5%	-3%
8	92	-4%	2%
9	86	-4%	6%
10	84	-1%	9%
11	85	3%	8%
12	86	6%	-1%
13	83	3%	-12%
14	77	2%	-17%
15	83	-5%	-8%
16	74	-10%	-14%

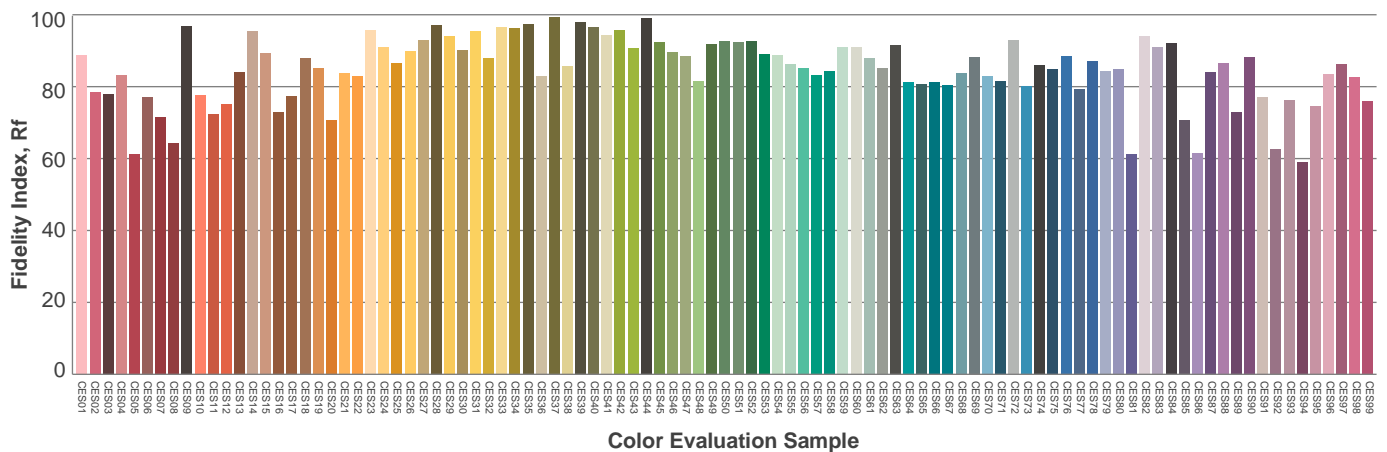
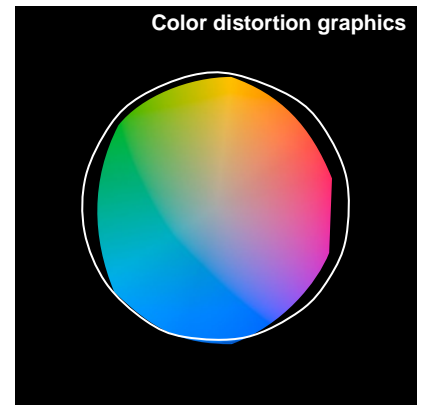
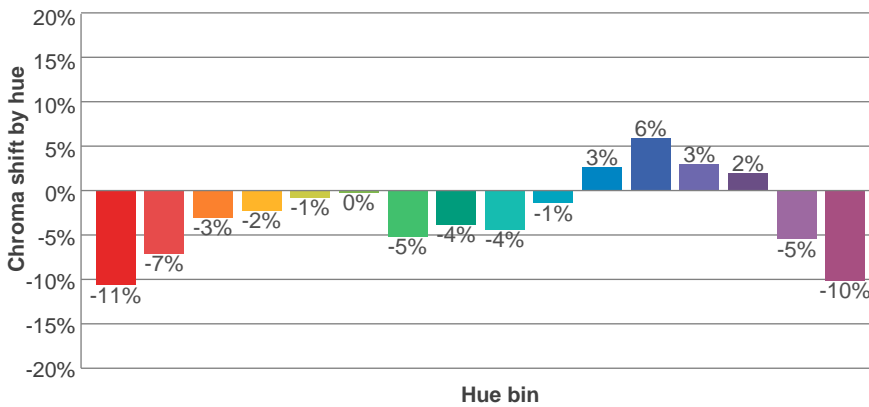
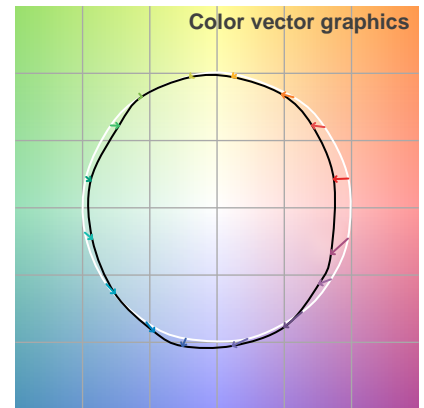
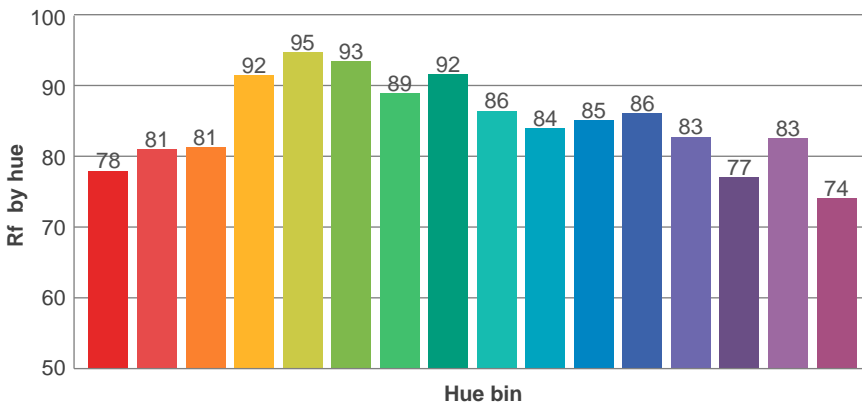
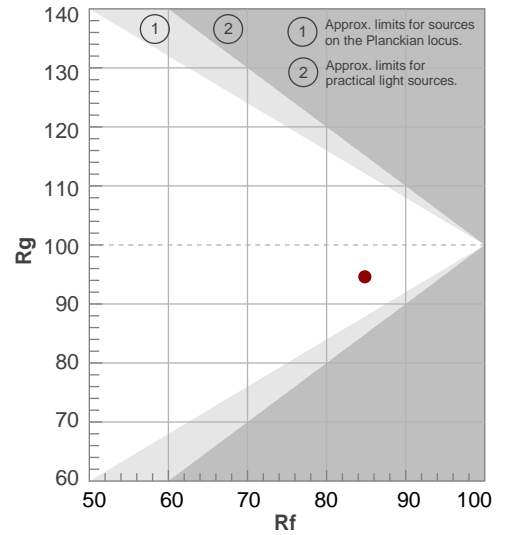

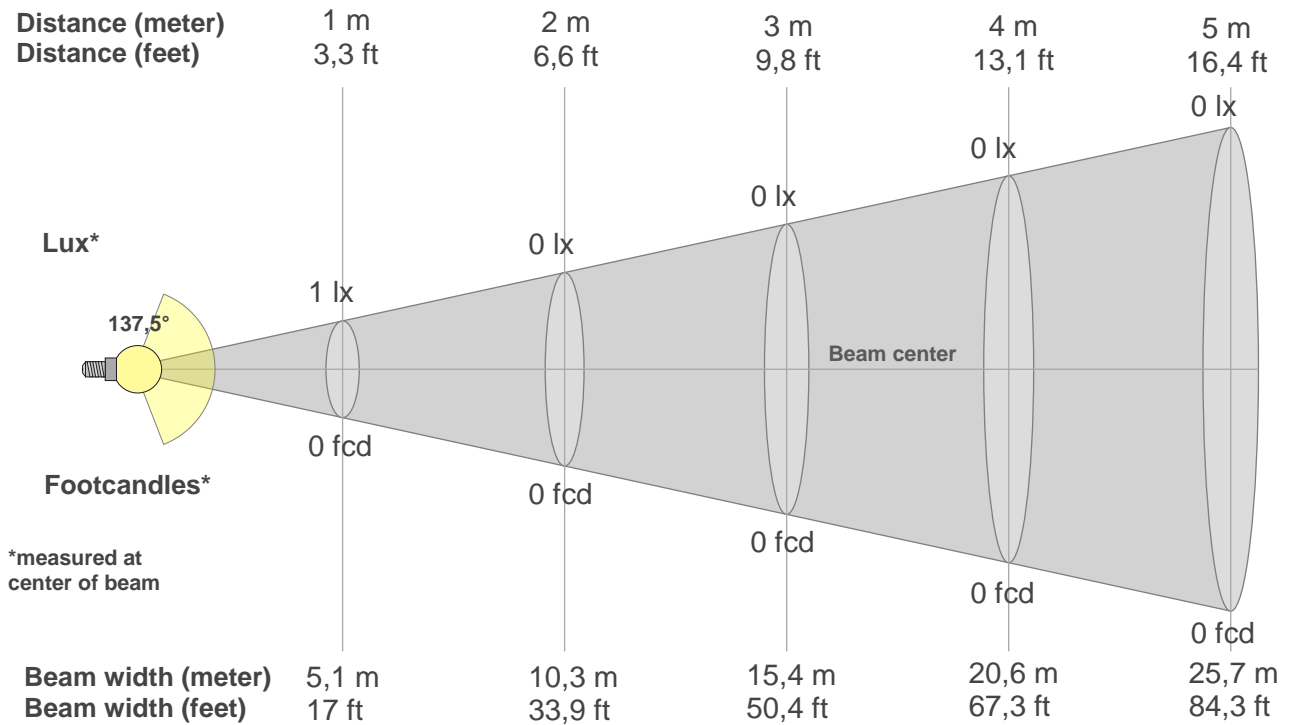

### Beam intensities from 1-20m

1m	2m	3m	4m	5m	6m	7m	8m	9m	10m	11m	12m	13m	14m	15m	16m	17m	18m	19m	20m
3,3ft	6,6ft	9,8ft	13,1ft	16,4ft	19,7ft	23ft	26,2ft	29,5ft	32,8ft	36,1ft	39,4ft	42,7ft	45,9ft	49,2ft	52,5ft	55,8ft	59,1ft	62,3ft	65,6ft
1lx	0lx	0lx	0lx	0lx	0lx	0lx	0lx	0lx	0lx	0lx	0lx	0lx	0lx	0lx	0lx	0lx	0lx	0lx	0lx
0,1fcd	0fcd	0fcd	0fcd	0fcd	0fcd	0fcd	0fcd	0fcd	0fcd	0fcd	0fcd	0fcd	0fcd	0fcd	0fcd	0fcd	0fcd	0fcd	0fcd

### Intensities in 0° c-plane

0°	5°	10°	15°	20°	25°	30°	35°	40°	45°	50°	55°	60°	65°	70°	75°	80°	85°	90°	95°
1,0	2,2	9,1	23,4	37,8	49,1	57,5	63,2	65,8	66,3	65,8	61,1	52,2	41,3	30,7	21,4	13,5	7,9	3,7	1,7
100%	217%	901%	2306%	3728%	4833%	5660%	6223%	6482%	6534%	6477%	6021%	5139%	4072%	3021%	2104%	1334%	782%	365%	169%

### Intensities in 90° c-plane

0°	5°	10°	15°	20°	25°	30°	35°	40°	45°	50°	55°	60°	65°	70°	75°	80°	85°	90°	95°
1,0	2,2	9,1	23,4	37,8	49,1	57,5	63,2	65,8	66,3	65,8	61,1	52,2	41,3	30,7	21,4	13,5	7,9	3,7	1,7
100%	217%	901%	2306%	3728%	4833%	5660%	6223%	6482%	6534%	6477%	6021%	5139%	4072%	3021%	2104%	1334%	782%	365%	169%

### Intensities in 180° c-plane

0°	5°	10°	15°	20°	25°	30°	35°	40°	45°	50°	55°	60°	65°	70°	75°	80°	85°	90°	95°
1,0	2,2	9,1	23,4	37,8	49,1	57,5	63,2	65,8	66,3	65,8	61,1	52,2	41,3	30,7	21,4	13,5	7,9	3,7	1,7
100%	217%	901%	2306%	3728%	4833%	5660%	6223%	6482%	6534%	6477%	6021%	5139%	4072%	3021%	2104%	1334%	782%	365%	169%

### Intensities in 270° c-plane

0°	5°	10°	15°	20°	25°	30°	35°	40°	45°	50°	55°	60°	65°	70°	75°	80°	85°	90°	95°
1,0	2,2	9,1	23,4	37,8	49,1	57,5	63,2	65,8	66,3	65,8	61,1	52,2	41,3	30,7	21,4	13,5	7,9	3,7	1,7
100%	217%	901%	2306%	3728%	4833%	5660%	6223%	6482%	6534%	6477%	6021%	5139%	4072%	3021%	2104%	1334%	782%	365%	169%

Beam angle 50%	Field angle 10%	Cutoff angle 2,5%	Intensity ratio in 120° cone	Intensity ratio in 90° cone
137,5°	172,6°	190,6°	68,6%	37,0%

### ISO candela diagram

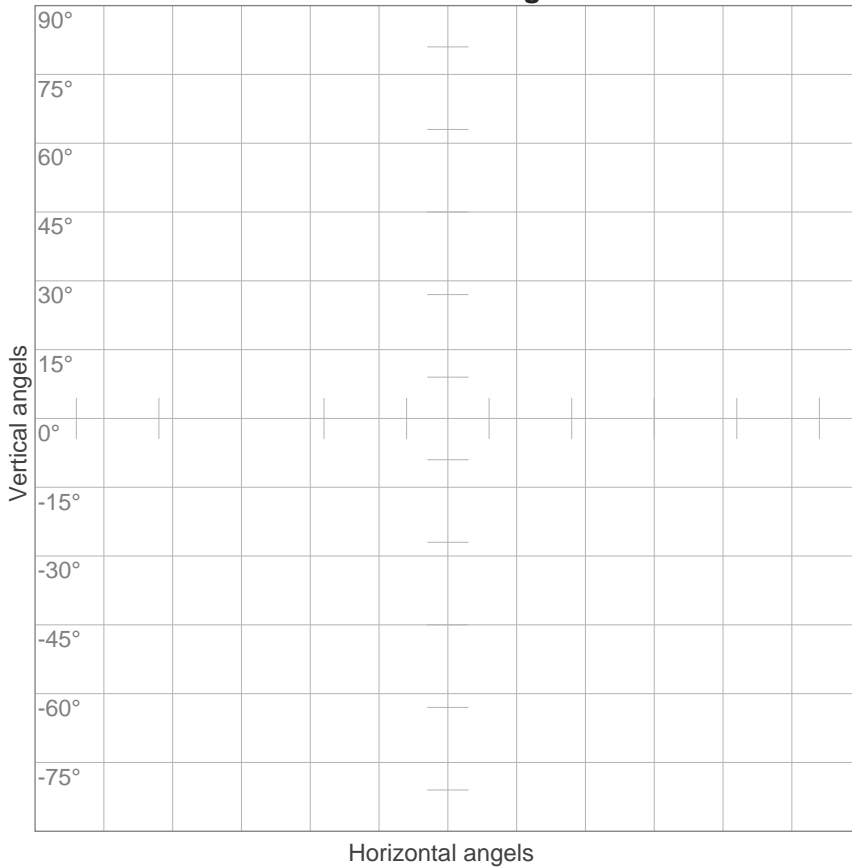

- 10% 0 cd
- 20% 0 cd
- 30% 0 cd
- 40% 0 cd
- 50% 1 cd
- 60% 1 cd
- 70% 1 cd
- 80% 1 cd
- 90% 1 cd

Conditions:

Number of c-planes: 24

Candela at center: 1 cd

### ISO lux diagram

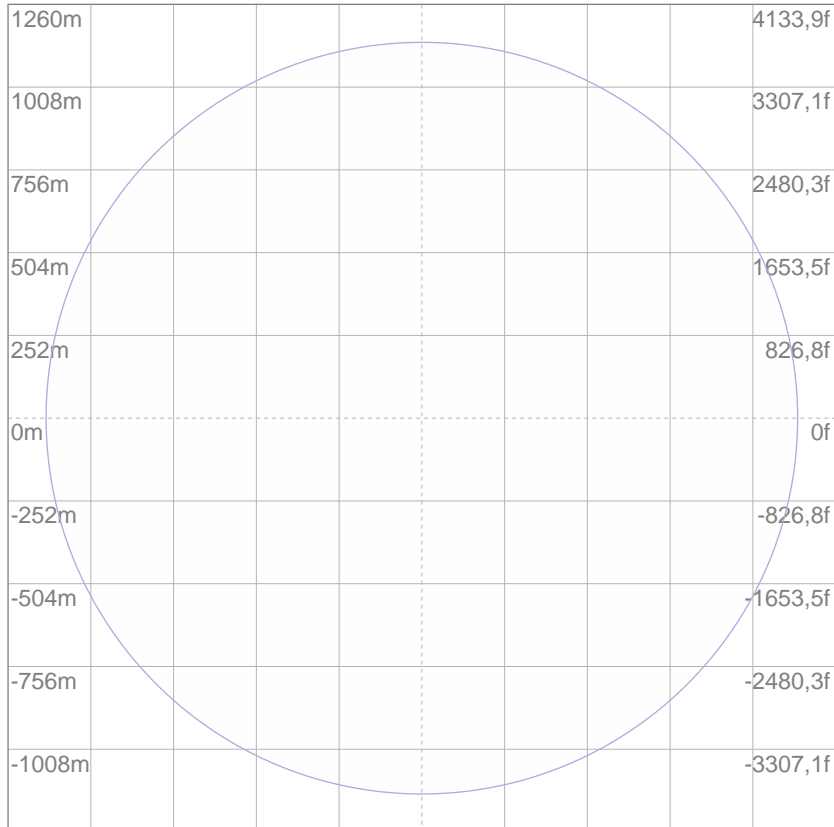

- 3% 305u lx
- 5% 508u lx
- 10% 1,02m lx
- 30% 3,05m lx
- 50% 5,08m lx

Conditions:

Number of c-planes: 24

Lux at center: 10,2m lx

*Lux distribution on a surface when lamp is mounted at 10 meters from the surface.*

**UGR**

## Glare Evaluation According to UGR

p Ceiling		70	70	50	50	30	70	70	50	50	30
p Walls		50	30	50	30	30	50	30	50	30	30
p Floor		20	20	20	20	20	20	20	20	20	20
Room size X    Y		Viewing direction at right angles to lamp axis					Viewing direction parallel to lamp axis				
2H	2H	25,3	26,8	25,7	27,1	27,5	25,3	26,8	25,7	27,1	27,5
	3H	26,9	28,3	27,3	28,6	28,9	26,9	28,3	27,3	28,6	28,9
	4H	27,5	28,8	27,9	29,1	29,5	27,5	28,8	27,9	29,1	29,5
	6H	28,0	29,2	28,4	29,5	29,9	28,0	29,2	28,4	29,5	29,9
	8H	28,2	29,3	28,6	29,7	30,1	28,2	29,3	28,6	29,7	30,1
	12H	28,3	29,4	28,8	29,8	30,2	28,3	29,4	28,8	29,8	30,2
4H	2H	26,0	27,3	26,4	27,7	28,0	26,0	27,3	26,4	27,7	28,0
	3H	27,8	28,9	28,2	29,3	29,7	27,8	28,9	28,2	29,3	29,7
	4H	28,5	29,5	29,0	29,9	30,3	28,5	29,5	29,0	29,9	30,3
	6H	29,1	30,0	29,6	30,4	30,9	29,1	30,0	29,6	30,4	30,9
	8H	29,4	30,2	29,9	30,6	31,1	29,4	30,2	29,9	30,6	31,1
	12H	29,6	30,3	30,1	30,8	31,3	29,6	30,3	30,1	30,8	31,3
8H	4H	28,8	29,6	29,3	30,0	30,5	28,8	29,6	29,3	30,0	30,5
	6H	29,6	30,2	30,1	30,7	31,2	29,6	30,2	30,1	30,7	31,2
	8H	29,9	30,5	30,5	31,0	31,6	29,9	30,5	30,5	31,0	31,6
	12H	30,3	30,8	30,8	31,3	31,9	30,3	30,8	30,8	31,3	31,9
12H	4H	28,8	29,6	29,3	30,0	30,5	28,8	29,6	29,3	30,0	30,5
	6H	29,7	30,2	30,2	30,7	31,3	29,7	30,2	30,2	30,7	31,3
	8H	30,1	30,6	30,6	31,1	31,7	30,1	30,6	30,6	31,1	31,7
Variation of the observer position for the luminaire distance S											
S = 1,0H		+0,1 / -0,1					+0,1 / -0,1				
S = 1,5H		+0,3 / -0,3					+0,3 / -0,3				
S = 2,0H		+0,5 / -0,6					+0,5 / -0,6				
Standard table		BK06					BK06				
Correction summand		12,9					12,9				
Corrected glare indices referring to 255 lm total luminous flux											

### Coefficients of Utilization

Ceiling reflectance	80				70				50			30			10			0
Wall reflectance	70	50	30	10	70	50	30	10	50	30	10	50	30	10	50	30	10	0
Floor reflectance	20	20	20	20	20	20	20	20	20	20	20	20	20	20	20	20	20	0
<b>RCR</b>	<b>(RCR: Room Cavity Ratio)</b>																	
	Room Values are expressed as percentage of Lumens delivered to the task surface																	
0	118	118	118	118	115	115	115	115	109	109	109	104	104	104	99	99	99	97
1	106	100	95	91	103	98	93	89	93	89	86	88	85	82	84	82	79	77
2	95	85	77	71	92	83	76	69	79	73	67	75	70	65	71	67	63	61
3	85	73	63	56	82	71	62	55	67	60	54	64	58	52	61	56	51	48
4	76	63	53	45	74	61	52	45	58	50	44	55	48	43	53	47	42	39
5	69	55	45	37	67	53	44	37	51	42	36	48	41	35	46	40	34	32
6	63	48	38	31	61	47	37	31	45	36	30	43	35	29	41	34	29	27
7	58	43	33	26	56	42	32	26	40	31	25	38	30	25	36	30	24	22
8	53	38	29	22	51	37	28	22	36	27	22	34	27	21	33	26	21	19
9	49	34	25	19	47	34	25	19	32	24	19	31	24	18	29	23	18	16
10	46	31	22	17	44	30	22	17	29	22	16	28	21	16	27	20	16	14

LAMPS (number of lamps)

### Luminaire budgetary diagram

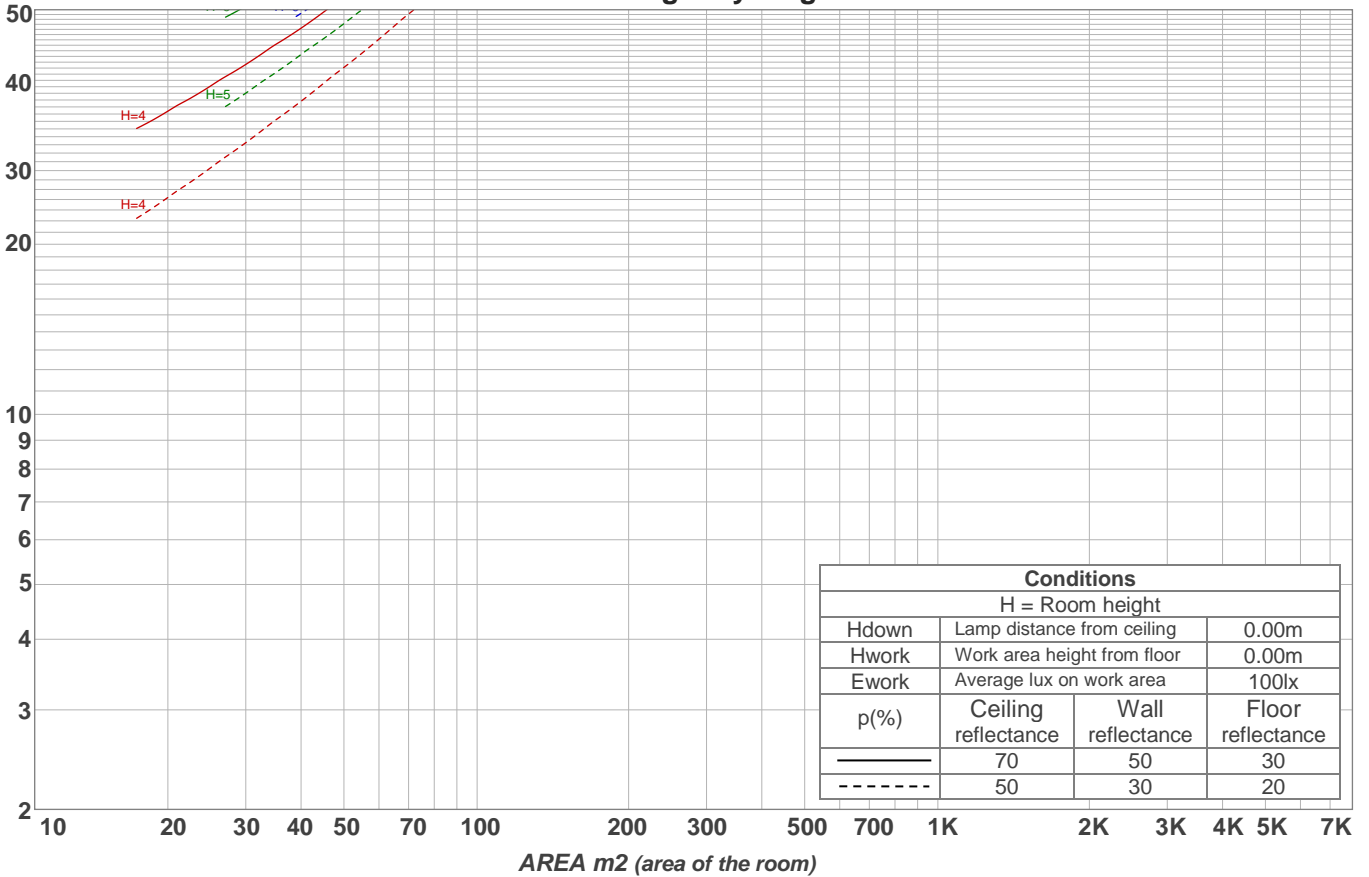

### Zonal Lumen Summary

0°-10°	10°-20°	20°-30°	30°-40°	40°-50°	50°-60°	60°-70°	70°-80°	80°-90°
0,431 lm	7,08 lm	22,8 lm	39,4 lm	51,2 lm	53,9 lm	40,9 lm	22,7 lm	8,80 lm
90°-100°	100°-110°	110°-120°	120°-130°	130°-140°	140°-150°	150°-160°	160°-170°	170°-180°
2,03 lm	1,17 lm	1,33 lm	1,25 lm	0,709 lm	0,449 lm	0,358 lm	0,225 lm	0,070 lm

